

10.4" Liquid Crystal Panel Mount Display

Key Features

- 10.4" Color Active Matrix Liquid Crystal Display
- 800 x 600 (SVGA)
- 400 cd/m² Brightness
- Built-in CPU
- 500 MHz processor, 256M DRAM, and 1MB Bios Flash
- Ethernet, Compact Flash, Mouse, Keyboard, and IDE Connections
- EMI Anti-Reflective Protective Window
- Designed and Built to Military Standards
- Wide Viewing Angle ± 70 Degrees



Model: REP-10CPU-PM

The REP-10CPU-PM is Epsilon Systems' 10.4" display and has a built-in CPU offering significant benefits with respect to dimensions, ruggedization and video quality. It has an Ethernet connection, a PS2 mouse and keyboard ports. The REP-10CPU-PM combines unmatched mechanical integrity with exceptionally low weight to provide a unique, rugged display solution, especially for applications where space and weight are critical.

The REP-10CPU-PM has a native resolution of 800 x 600 (SVGA) offering excellent performance in terms of brightness, crispness, contrast and viewing angle. The bezel and mounting can be customized to address virtually any mounting need in any application. Additionally, the REP-10CPU-PM combines this high level of performance and versatility with a very competitive price/performance value.

Epsilon Systems' display has been designed and qualified for applications in the most hostile environments. Epsilon Systems' rugged displays are well suited for specific naval combat, army and airborne applications.

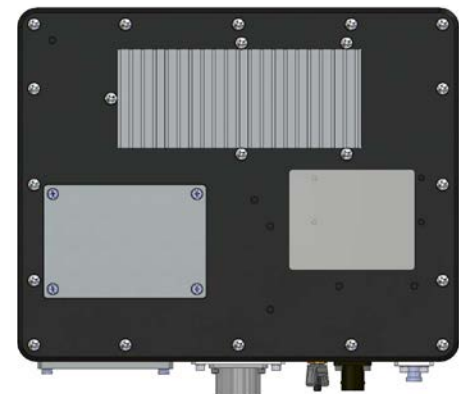

BACK



BOTTOM

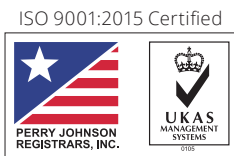

10.4" Liquid Crystal Panel Mount Display

Contact

Brian Gallatin

Vice President & GM,
Advanced Products Group

757-961-4526

FlatPanels@epsilonsystems.com

5482 Complex Street, Suite 109
San Diego, CA 92123

619-702-1700

Headquarters and Corporate Office
9242 Lightwave Ave., Suite 100
San Diego, CA 92123

TECHNICAL SPECIFICATIONS

Active Display Area	10.4" TFT Active Matrix LCD 211.2 x 158.4 mm (8.32" x 6.24")
Display Resolution	800 x 600 (SVGA)
LCD Technology	CCFL Backlighting
Input Interface	Ethernet, Compact Flash, Mouse, Keyboard, and IDE
Brightness	400 cd/m2
Viewing Angle	± 70 Degrees All Directions (Typical)
Contrast Ratio	500:1 (Typical)
Display Colors	16.7 M
Power Supply	115 VAC
Model Number	REP-10CPU-PM
User Controls	Brightness/Dim, Power

DESIGNED TO MEET RIGOROUS MILITARY SPECIFICATIONS

MIL-STD-167-1, Type 1	Vibration
MIL-STD-810	Environmental
MIL-STD-901D Grade A, Class I, Type A	Shock
MIL-STD-461E	EMI/EMC

ENVIRONMENTAL SPECIFICATIONS

IP Rating	IP65 Drip Proof
Operating Temperature	0°C to 60°C
Storage Temperature	-20°C to +80°C
Humidity	5 to 95% @ RH Non-condensing

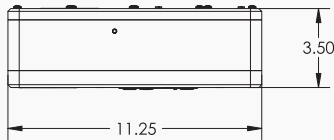

TOP

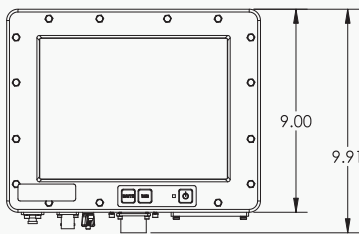

FRONT

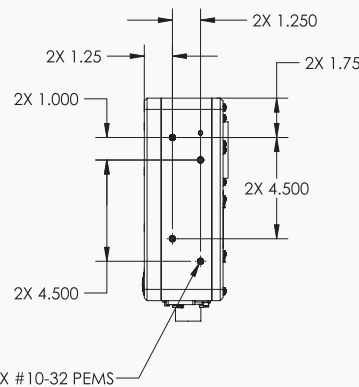

SIDE

DIMENSIONS INCHES MILLIMETERS

Height	9.06"	230.2 mm
Width	11.25"	285.75 mm
Depth	3.75"	95.3 mm
Weight	14 lbs	6.4 kg