

## Rugged Engineered Products



### 17" Display

Model: REP-17-115VAC

#### KEY FEATURES

- 17.0" Color Active Matrix Liquid Crystal Display
- Resolution 1280 x 1024 (SXGA)
- Designed and Built to Military Standards
- VGA (Standard)  
DVI (Optional)  
NTSC (Optional)
- Bonded Anti-Reflective Protective Window
- Military-Grade Video and Power Input Connectors
- Touch Screen (Optional)

The REP-17-115VAC is Epsilon's 17" display offering significant benefits with respect to dimensions, viewing angle, ruggedization and video quality. The 17 display combines unmatched mechanical integrity with exceptionally low weight to provide a unique, rugged display solution, especially for applications where space and weight are critical.

The REP-17-115VAC features a 17" Active Matrix Liquid Crystal Display 1280 x 1024 (SXGA) offering excellent performance in terms of brightness, crispness, contrast and viewing angle. The bezel and mounting can be customized to address virtually any mounting need in any application. Additionally, the REP-17-115VAC combines this high level of performance and versatility with a very competitive price/performance value.

Epsilon's displays have been designed and qualified for application in the most hostile environments. Epsilon's rugged displays are well suited for specific naval combat, army and airborne applications.

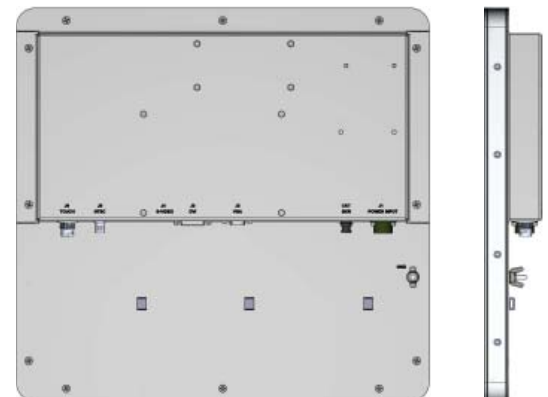

## TECHNICAL SPECIFICATIONS

Active Display Area	17" TFT Active Matrix LCD
Display Resolution	1280 x 1024 (SXGA)
LCD Technology	CCFL Backlighting
Input Interface	VGA, NTSC (Optional), DUI (Optional)
Brightness	280 cd/m <sup>2</sup> (Minimum)
Viewing Angle	± 89 Degrees All Directions (Typical)
Contrast Ratio	1500:1 (Typical)
Display Colors	16M
Power Supply	115VAC
Model Number	REP-17-115VAC
User Controls	Bright/Dim, Menu, Source

## RIGOROUS MILITARY SPECIFICATIONS

MIL-STD-167-1, Type 1	Vibration
MIL-STD-810	Environmental
MIL-STD-901D Grade A, Class I, Type A	Shock
MIL-STD-461E	EMI/EMC

## ENVIRONMENTAL SPECIFICATIONS

IP Rating	IP65 Drip Proof
Operating Temperature	0°C to 50°C
Storage Temperature	-20°C to +60°C
Humidity	5 to 95% @ RH Non-condensing
Altitude	0 to 15,000 ft. above sea level (Up to 40,000 ft. storage)

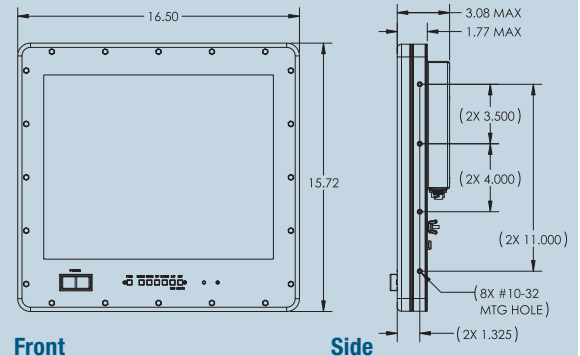

Top

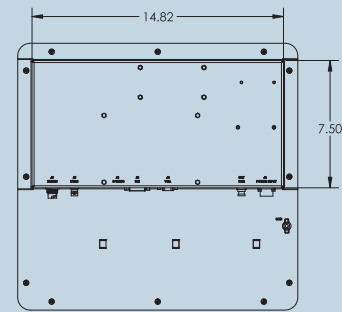

Back

DIMENSIONS	INCHES	MILLIMETERS
Height	15.72"	399.288 mm
Width	16.50"	419.1 mm
Depth	3.08"	81.2 mm
Weight	18 lbs	8.6 kg

Shown with Optional Mounting Brackets for a 19" Rack



REP-17-115VAC\_REV-C

### Business Development Manager

Rugged Engineered Products Sector

(T) 619-702-1700

(E) REPInfo@epsilonsystems.com

### Rugged Engineered Products Sector

5482 Complex Street, Suite 109

San Diego, CA 92123

(T) 619-702-1700

### Headquarters and Corporate Office

9242 Lightwave Ave., Suite 100

San Diego, CA 92123